

HydroFlush



The HydroFlush is suitable for pumping shower water to a higher level when gravity drainage is not possible and/or economical to install.

The compact HydroFlush chamber offers a low level inlet suitable for accepting the waste from a standard shower tray trap. The slim line design allows concealed installation underneath a raised shower tray for inconspicuous installation.

The system consists of a sealed polyethylene chamber, internal and external pipe work and fittings, automatic vortex pump and uPVC outlet connection.

KEY FEATURES

- Designed to accept waste from all conventional shower tray traps
- Concealed installation possible using raised shower tray
- 22 mm discharge allows pumping through small bore pipes

WASTE



Grey

DIMENSIONS (mm)

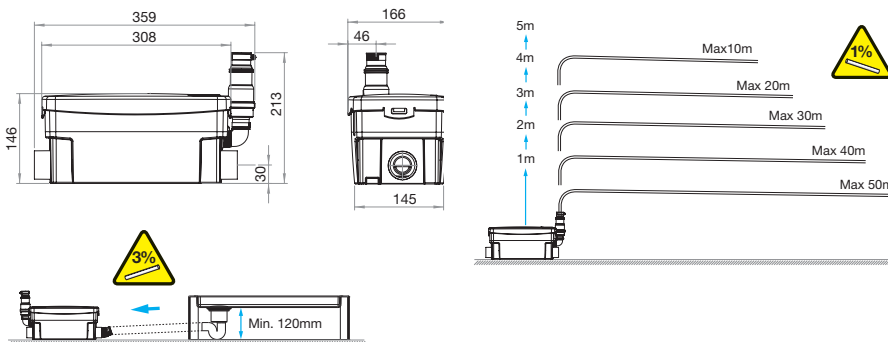

TECHNICAL DATA

Power supply	230 V 50Hz ~1
Rated current	1.3 A
Motor rating	250 W
Max vertical output	5 m
Max horizontal output	50 m
Horizontal fall	1:100
Activation level	65 mm
Shower tray height	120 mm
Max flow rate	70 l/m
Max liquid temperature	<35°C intermittent
Inlet number	2
Inlet size	40 mm
Discharge size	22 mm
Cable length	1 m
Weight	3.5 kg
Low noise level	40 dB(A)
IP rating	IP44
Colour	White

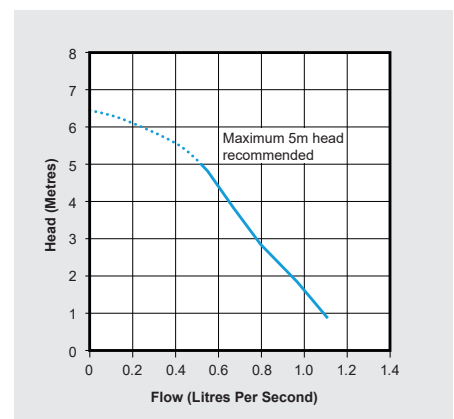

DELIVERING PUMPED AND DRAINAGE SOLUTIONS FOR OVER 30 YEARS

- Packaged pumping stations
- Waste water pumping systems
- Macerators and macerating toilets
- Floor mounted pumping stations
- Fat, oil and grease separating systems
- Rainwater harvesting systems
- Battery backup systems
- Adoptable pumping stations
- Submersible pumps
- Accessories



We provide pumped and drainage products and services to the public and private sectors including residential, commercial, hospitality and retail. We are proud of the long-term relationships we have built with clients and partners, delivering cost effective, robust and dependable products and services.

12-MONTH GUARANTEE

Your products are protected by a 12-month guarantee. [Terms and Conditions](#) apply.

HOW TO ORDER

Order online at www.edincare.com
 Call Sales on 01442 211554
 Email sales@edincare.com

PROJECT SERVICES

- Project design
- Site surveys
- Installations
- Refurbishments

AFTERSALES SERVICES

- Planned servicing
- Emergency call outs
- Commissioning
- Monitoring

DRAINAGE SERVICES

- Tankering
- Drain maintenance
- Surveys and investigations
- Repairs

www.edincare.com

- Discover our products and services
- Order products online
- Case studies and articles
- Brochures and technical documents

Protect your property with an Edincare Service Agreement

As with all pumped and drainage systems, regular maintenance is essential to ensure optimum performance and minimal downtime. Our Service Agreements comprises planned preventive maintenance visits at an agreed frequency, we also service other manufacturers' equipment regardless of type, make and age.

- ✓ Validates your building insurance
- ✓ Reduces the risk of failure
- ✓ Increases the life expectancy of your equipment
- ✓ Priority callouts and 24/7 out-of-hours service
- ✓ Reduced rates for emergency call outs
- ✓ Flexible payment options (Direct Debit)



+44 (0)1442 211554
info@edincare.com

www.edincare.com
 [edincarepumps](https://www.linkedin.com/company/edincarepumps)

Unit 7, Heron Business Park, Eastman Way,
 Hemel Hempstead, Hertfordshire, HP2 7FW

A Tricel Company
www.tricel.ie



Our policy is one of continuous product improvement, we reserve the right to change specifications and prices without prior notice. All information is given in good faith. No responsibility can be accepted for errors, omissions or incorrect assumptions.
 © 2025 Omni Pump International Ltd t/a Edincare Pumps & Edincare Drains.