

AutoFlushSSCSL Twin c/w Timer Control Panel

The AutoFlushSSTwin is a fully automatic pumping station suitable for pumping grey water with small solids (smaller than 5 mm in diameter) to a higher level when gravity drainage is not possible and/or economical to install.

Its chemically resistant pumps feature seals designed to withstand immersion in aggressive chemicals.

The compact chamber is ideal for accepting waste from laboratories, photo developing stations, process wastes or similar.

The system consists of a sealed stainless steel, internal pipe work and fittings, chemically-resistant automatic vortex submersible pumps and male-threaded outlet connection.

1½" BSP discharge allows small bore pipe work for installation through busy service voids and roof spaces.

A 10-hour changeover control panel offers even wear for the two motors as well as a high level alarm and volt-free contact.



WASTE TYPE



Grey Chemical

KEY FEATURES

- Chemically resistant pumps with seals designed to withstand immersion in aggressive chemicals
- Twin pumps to protect against pump failure and heavy water inflows
- Control panel for timed changeover, high level alarm and volt-free contact
- Reliable automatic pumps suitable for soft solids up to 5 mm in diameter
- Installation of an optional low level float
- High-grade stainless steel chamber with easy to clean finish
- 1½" BSP discharge for pumping of wastewater through small bore pipes

PUMP CURVE

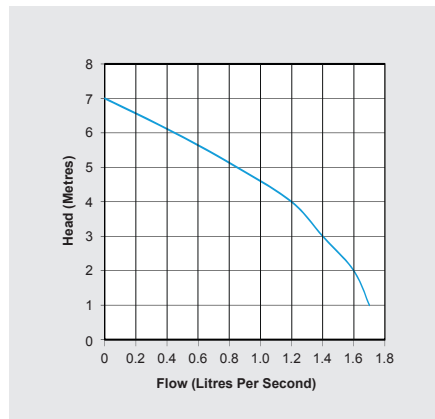

TECHNICAL DATA

Tank	
Material	Stainless steel
Lifting eyes	No
Capacity	90 litres
External discharge size	1½" BSP
Pump	
Number of pumps	2
Power supply	230 V AC 50 Hz
Rated current	1.4 A
Motor rating	200 W
Revolutions per min.	2720 rpm
Max vertical output	7 m
Max flow rate	1.7 l/s
Max liquid temp.	<40°C
Discharge size	1½"
Free passage	10 mm
Cable length	3 m
Control panel	
Material	Metal
Volt-free contact	Yes, common fault
Voltage	240 V
Volted contact	24 V
IP rating	IP54
Dimensions (L x W x D)	400 mm x 400 mm x 200 mm
Float	
Material	Polyethylene
Cable length	10 m

DIMENSIONS (mm)

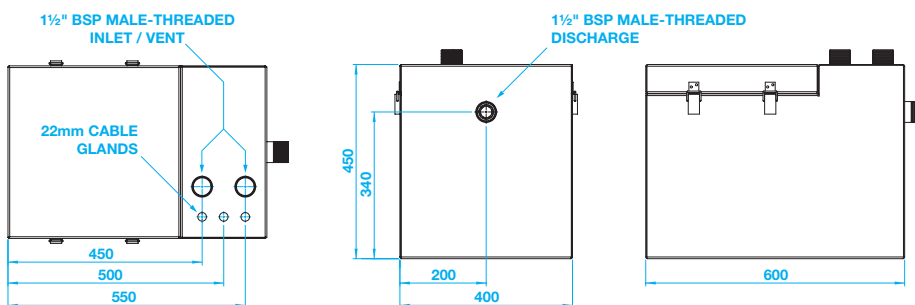

RECOMMENDED ACCESSORIES AND PRODUCTS



All our products can be customised to your requirements. For more information please call our sales team on 01442 211554.

DELIVERING PUMPED AND DRAINAGE SOLUTIONS FOR OVER 30 YEARS



We provide pumped and drainage products and services to the public and private sectors including residential, commercial, hospitality and retail. We are proud of the long-term relationships we have built with clients and partners, delivering cost effective, robust and dependable products and services.

12-MONTH GUARANTEE

Your products are protected by a 12-month guarantee. [Terms and Conditions](#) apply.

HOW TO ORDER

Order online at www.edincare.com
 Call Sales on 01442 211554
 Email sales@edincare.com

www.edincare.com

- Discover our products and services
- Order products online
- Case studies and articles
- Brochures and technical documents

PROJECT SERVICES

- Project design
- Site surveys
- Installations
- Refurbishments

AFTERSALES SERVICES

- Planned servicing
- Emergency call outs
- Commissioning
- Monitoring

DRAINAGE SERVICES

- Tankering
- Drain maintenance
- Surveys and investigations
- Repairs

Protect your property with an Edincare Service Agreement

As with all pumped and drainage systems, regular maintenance is essential to ensure optimum performance and minimal downtime. Our Service Agreements comprises planned preventive maintenance visits at an agreed frequency, we also service other manufacturers' equipment regardless of type, make and age.

- ✓ Validates your building insurance
- ✓ Reduces the risk of failure
- ✓ Increases the life expectancy of your equipment
- ✓ Priority callouts and 24/7 out-of-hours service
- ✓ Reduced rates for emergency call outs
- ✓ Flexible payment options (Direct Debit)



+44 (0)1442 211554
info@edincare.com

www.edincare.com
 [edincarepumps](https://www.linkedin.com/company/edincarepumps)

Unit 7, Heron Business Park, Eastman Way,
 Hemel Hempstead, Hertfordshire, HP2 7FW

A Tricel Company
www.tricel.ie



Our policy is one of continuous product improvement, we reserve the right to change specifications and prices without prior notice. All information is given in good faith. No responsibility can be accepted for errors, omissions or incorrect assumptions.
 © 2025 Omni Pump International Ltd t/a Edincare Pumps & Edincare Drains.