

ProTrap Auto 1850-AST-PF

The ProTrap Auto 1850-AST-PF is a fully automatic grease separation and solids removal system suitable for the collection, separation and removal of food waste and fat, oil and grease (FOG) from grey water before the final discharge.

It is suitable for pot wash, double bowl and pre-rinse sinks, hooded and under-counter dishwashers up to a total flow rate of 1.85 l/s.

FOG and solid food waste is collected in interchangeable pre-filter basket and solids container for daily emptying.

Protect the environment and prevent recurring drain blockages caused by FOG. Comply with local water authority and landlord requirements.

The ProTrap Auto is very easy and quick to maintain. Kitchen staff do not need to access the internals of the machine.

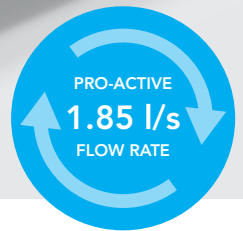

APPLICATIONS



FLOW RATES & CERTIFICATION

- Pro-active flow rate – 1.85 l/sec
- ASME Certification
- PDI Certification
- CSA Certification
- EN 1825 Certification

Do not exceed the rated flows.

STANDARD FEATURES & FUNCTIONS

- Fully automatic and self-cleaning
- Magnetic baffle for bioremediation
- PLC controlled
- No requirement for enzymes or bio additives
- No heating element, so no risk of fire and very low energy consumption
- Non-restricted Vortex Flow Control device
- Reverse flow configuration
- Space saver running trap and sampling point

EASY TO MAINTAIN

- No access to the unit's internals is necessary
- FOG collects in an easy to clean external container for daily emptying
- Solid food waste collects in interchangeable pre-filter basket and solids container for daily emptying

TECHNICAL SPECIFICATIONS

PLUMBING CONNECTIONS

Pre-filter inlet	1½" / 40 mm
Inlet	1½" / 40 mm
Invert inlet	1¼" / 32 mm
Outlet	2" / 50 mm
Decant outlet	¾" / 18 mm
Hot water solenoid	¾" / 22 mm

ELECTRICAL RATINGS

Voltage	230 V
Current	0.49 A
Av. power consumption	47.6 W ph

STANDARD OPERATIONAL TIMES

Days of operation	7 days a week
Hours of operation	07:00–02:30

Note: Operational times should be adjusted to suit the needs of the kitchen

⚠️ AQUACHECK 15DN (WRAS Certified) or equivalent double check valve must be fitted to water supply on all ProTrap Auto models to conform with WRAS back flow prevention.

WASTE



Grey

Need help choosing the correct grease trap for your kitchen?

Call our Sales Team on 01442 211554 for free no-obligation advice including how to comply with local authority and landlord regulations. We offer site surveys, installation and servicing.

ProTrap Auto 1850-AST-PF

DIMENSIONS

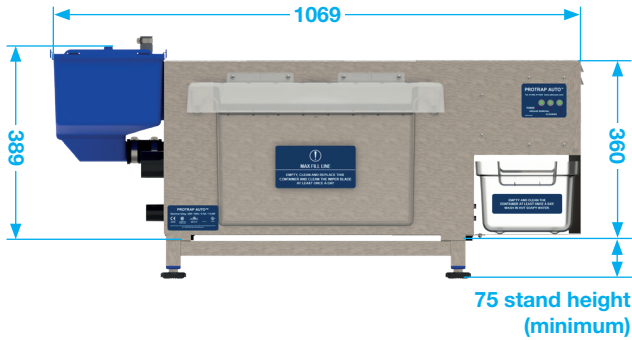

HEIGHT REQUIRED FOR FILTER BASKET REMOVAL



SPACE REQUIRED FOR END PLATE REMOVAL AND ACCESS

DECANT OUTLET Ø 3/4" (18 mm) OUTLET Ø 2" (50 mm) SPACE REQUIRED FOR SOLIDS CONTAINER REMOVAL

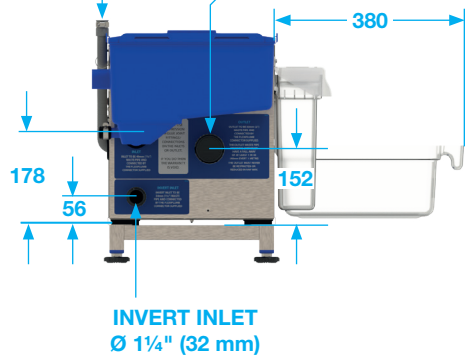

ACCESSORIES & SPARES



PROTRAP AUTO PREFILTER BASKET (FULL KIT)

Product code: #55013



SEPARATOR PRO STANDARD WITH STAND & COFFEE BASKET

Product code: #55015



PROTRAP AUTO 1850 FOG TANK

Product code: #55017

CERTIFICATIONS & APPROVALS

ASME A112.14.3-2000 Testing of Grease Interceptors, ASME A112.14.4-2001 Grease Removal Devices, CSA B481.0-2012 Testing of Grease Interceptors, CSA B481.1-2012 Testing and Rating of Grease Interceptors using Lard, CSA B481.5-2012 Testing and Rating of Grease Interceptors Equipped with a Grease Removal Device & PDI G 101. UL Approved (File No: E361705). Machinery Directive 2006/42/EC and EMC directive 2004/108/EC.

DELIVERING PUMPED AND DRAINAGE SOLUTIONS FOR OVER 30 YEARS

- Packaged pumping stations
- Waste water pumping systems
- Macerators and macerating toilets
- Floor mounted pumping stations
- Fat, oil and grease separating systems
- Rainwater harvesting systems
- Battery backup systems
- Adoptable pumping stations
- Submersible pumps
- Accessories



We provide pumped and drainage products and services to the public and private sectors, including residential, commercial, hospitality and retail.

We are proud of the long-term relationships we have built with our clients and partners, delivering cost effective, robust and dependable products and services.

12-MONTH GUARANTEE

Your products are protected by a 12-month guarantee. Please refer to our Terms and Conditions at www.edincare.com

HOW TO ORDER

Order online at www.edincare.com
 Call Sales on 01442 211554
 Email sales@edincare.com

PROJECT SERVICES

- Project design
- Site surveys
- Installations
- Refurbishments

AFTERSALES SERVICES

- Planned servicing
- Emergency call outs
- Commissioning
- Monitoring

DRAINAGE SERVICES

- Tankering
- Jetting
- Drainage CCTV
- Surveys
- Cleaning and de-scaling
- Structural repairs
- Excavations
- Root cutting

www.edincare.com

- Discover our products and services
- Order products online
- Case studies and articles
- Brochures and technical documents

Protect your property with an Edincare Service Agreement

As with all pumped and drainage systems, regular maintenance is essential to ensure optimum performance and minimal downtime. Our Service Agreements comprises planned preventive maintenance visits at an agreed frequency, we also service other manufacturers' equipment regardless of type, make and age.

- ✓ Validates your building insurance
- ✓ Reduces the risk of failure
- ✓ Increases the life expectancy of your equipment
- ✓ Priority callouts and 24/7 out-of-hours service
- ✓ Reduced rates for emergency call outs
- ✓ Flexible payment options (Direct Debit)



+44 (0)1442 211554
info@edincare.com

www.edincare.com
[edincarepumps](https://www.linkedin.com/company/edincarepumps)

Unit 8, Heron Business Park, Eastman Way,
 Hemel Hempstead, Hertfordshire, HP2 7FW

Part of the Edincare Group of Companies www.edincaregroup.com



Our policy is one of continuous product improvement, we reserve the right to change specifications and prices without prior notice. All information is given in good faith. No responsibility can be accepted for errors, omissions or incorrect assumptions. © Omni Pump International Ltd t/a Edincare Pumps & Edincare Drains. All rights reserved.