

MagnaCompact Macerator

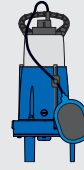

SYSTEM OVERVIEW



One free-standing automatic pump

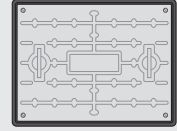

Access cover, solid top, locking, galvanised steel, PP frame, FACTA A



1 1/4" Class E PVC pipework



110 mm inlet



1 1/4" brass valves



50 mm cable duct



32 mm MDPE discharge



50 mm vent

The MagnaCompact Macerator is a fully automatic packaged pumping station suitable for pumping grey or foul water to a higher level when gravity drainage is not possible and/or economical to install.

The system provides up to 72 litre storage capacity depending inlet depth. It is ideal for accepting waste from an extension, outbuilding, basement or similar.

The pump's cutting action offers reliable and effective pumping of grey and foul water.

The system comprises a tank-grade polyethylene chamber, internal Class E PVC pipework and fittings, brass valves, a free-standing automatic pump with macerating impellor, and an external compression adaptor for discharge to 32 mm OD MDPE.

A solid top, locking, galvanised steel access cover is included (FACTA A). Alternative access covers are available to suit your project requirements.

It is easy to install as inlets can be positioned to your site's requirements. Inlet information to be supplied at time of order, or can be drilled on site.

Our packaged pumping stations are built to last and designed to be easy to service.

KEY FEATURES

- Macerator impellor
- Up to 72 litres storage capacity depending on inlet depth
- 60° benching
- Compact chamber for limited space installations
- Ideal for an extension, outbuilding, basement or similar
- 600 mm x 450 mm clear opening
- Variable inlet positions to suit site
- A range of alarms and remote alerts are available offering peace of mind
- Quick and simple to install

SPECIFICATIONS

MagnaProCompact Macerator complies with:

- BS EN 12050-1:2015 Wastewater lifting plants for buildings and sites. Lifting plants for wastewater containing faecal matter.



We recommend an AquaSafe Alarm (Sump) is purchased with each MagnaCompact system.
Product code: 22071

WASTE TYPE



Grey

Foul

OPTIONAL EXTRAS



Upgraded pumps

Control equipment

Battery backup

External pipework

Remote monitoring

Level controls

Access covers

Kiosks

All our products can be customised to your requirements. For more information and advice please call our Sales Team on 01442 211554.

MagnaCompact Macerator

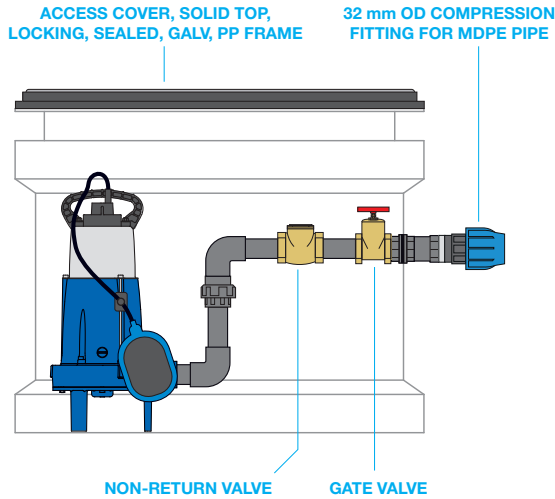

CONNECTIONS POSITIONED ACCORDING TO SITE REQUIREMENTS



PUMP SPECIFICATIONS

Number of pumps	One
Impellor type	Macerator
Control	Automatic
Power supply	230 VAC
Rated current	6.4 A
Motor rating (P2)	1000 W
Revolutions per min.	2865
Discharge size	1¼"
Free passage	N/A
Max. vertical output	20 m
Max. flow rate	1.8 l/s
Max liquid temp.	<40 °C
Cable length	10 m
Weight	18 kg

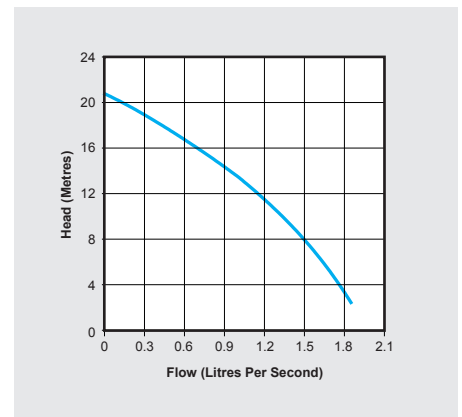

CHAMBER DIMENSIONS

Shows indicative capacities from lowest inlet invert.

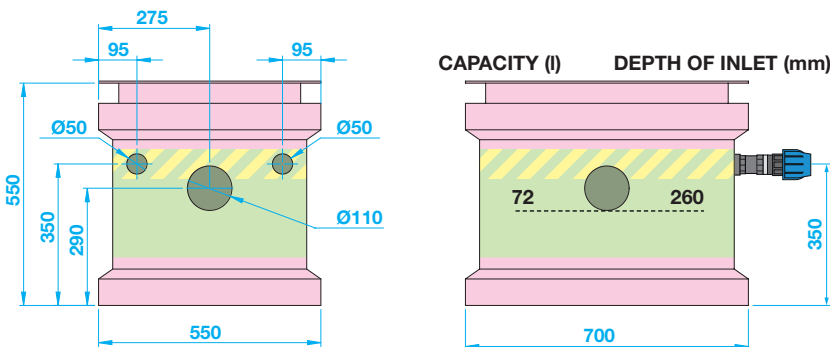

Permitted connection positions

Discharge only	Inlet location allowed	Cable ducts and vents allowed	No drilling allowed
----------------	------------------------	-------------------------------	---------------------

CHAMBER SPECIFICATIONS

Internal pipework	1¼" OD Class E PVC
Discharge pipework	32 mm OD MDPE
Lifting eyes	No
Maximum storage capacity	72 litres
Chamber material	Tank-grade polyethylene
Dimensions (L x W x D)	700 x 550 x 550 mm
Clear opening	600 x 450 mm

ACCESS COVER

Material	Galvanised steel, PP frame
Cover type	Solid top
Locking	4 screws
Loading	Pedestrian duty FACTA A
Clear opening (H x W)	600 x 450 mm
Dimensions (L x W x D)	663 x 513 x 30 mm

DELIVERING PUMPED AND DRAINAGE SOLUTIONS FOR OVER 30 YEARS

- Packaged pumping stations
- Waste water pumping systems
- Macerators and macerating toilets
- Floor mounted pumping stations
- Fat, oil and grease separating systems
- Rainwater harvesting systems
- Battery backup systems
- Adoptable pumping stations
- Submersible pumps
- Accessories



We provide pumped and drainage products and services to the public and private sectors, including residential, commercial, hospitality and retail.

We are proud of the long-term relationships we have built with our clients and partners, delivering cost effective, robust and dependable products and services.

12-MONTH GUARANTEE

Your products are protected by a 12-month guarantee. Please refer to our Terms and Conditions at www.edincare.com

HOW TO ORDER

Order online at www.edincare.com
 Call Sales on 01442 211554
 Email sales@edincare.com

PROJECT SERVICES

- Project design
- Site surveys
- Installations
- Refurbishments

AFTERSALES SERVICES

- Planned servicing
- Emergency call outs
- Commissioning
- Monitoring

DRAINAGE SERVICES

- Tankering
- Jetting
- Drainage CCTV
- Surveys
- Cleaning and de-scaling
- Structural repairs
- Excavations
- Root cutting

www.edincare.com

- Discover our products and services
- Order products online
- Case studies and articles
- Brochures and technical documents

Protect your property with an Edincare Service Agreement

As with all pumped and drainage systems, regular maintenance is essential to ensure optimum performance and minimal downtime. Our Service Agreements comprises planned preventive maintenance visits at an agreed frequency, we also service other manufacturers' equipment regardless of type, make and age.

- ✓ Validates your building insurance
- ✓ Reduces the risk of failure
- ✓ Increases the life expectancy of your equipment
- ✓ Priority callouts and 24/7 out-of-hours service
- ✓ Reduced rates for emergency call outs
- ✓ Flexible payment options (Direct Debit)



+44 (0)1442 211554
info@edincare.com

www.edincare.com
[edincarepumps](https://www.linkedin.com/company/edincarepumps)

Unit 8, Heron Business Park, Eastman Way,
 Hemel Hempstead, Hertfordshire, HP2 7FW

Part of the Edincare Group of Companies www.edincaregroup.com



Our policy is one of continuous product improvement, we reserve the right to change specifications and prices without prior notice. All information is given in good faith. No responsibility can be accepted for errors, omissions or incorrect assumptions. © Omni Pump International Ltd t/a Edincare Pumps & Edincare Drains. All rights reserved.