

# SumpFlushHP 650-1000

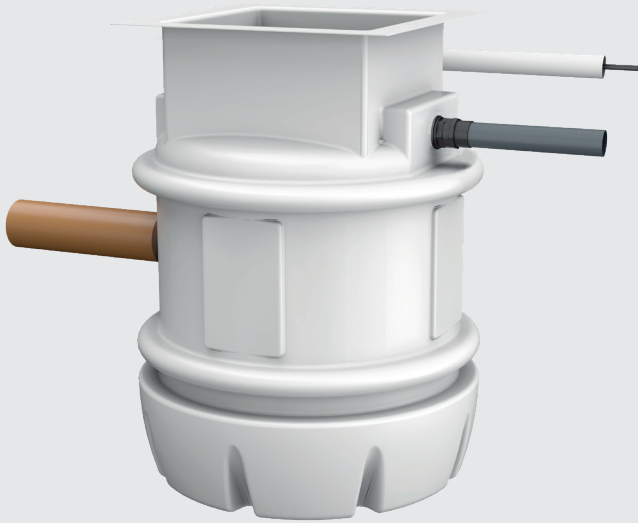

## SYSTEM OVERVIEW

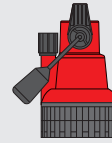

One powerful free-standing automatic pump

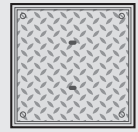

Access cover, solid top, locking, galvanised steel, FACTA A



1 1/4" Class E PVC pipework



110 mm inlet



1 1/4" Class E PVC discharge



50 mm cable duct

The SumpFlushHP 650-100 is a fully automatic wastewater pumping system suitable for pumping surface and/or ground water to a higher level when gravity drainage is not possible and/or economical to install.

It features a powerful submersible pump for high head (up to 12 m) and flow (up to 4 l/s) applications.

The system provides up to 165 litre storage capacity depending inlet depth. It can accept waste from car parks, car washes, floor areas, down pipes, cavity membrane systems or similar.

It is not suitable for receiving foul waste. Contact our Sales Team for advice on a suitable foul water packaged pumping stations for your property.

The system consists of a polyethylene tank, a powerful automatic wastewater submersible pump and solid top, locking, galvanised steel access cover (FACTA A).

It discharges to solvent welded 1 1/4" Class E PVC. Optional discharge reducer kits can increase external discharge diameter to 1 1/2" or 2" to reduce friction loss.

It is easy to install as inlets can be positioned to your site's requirements. Inlet information to be supplied at time of order, or can be drilled on site.

## KEY FEATURES

- Powerful vortex pump for high head and flow
- Up to 165 litres storage capacity
- Compact chamber for limited space installations
- Ideal for an extension, outbuilding, basement or similar
- 450 mm x 450 mm clear opening
- Variable inlet positions to suit site
- A range of battery backup systems are available
- A range of alarms and remote alerts are available
- Quick and simple to install

## WASTE TYPE



Grey



Ground



Surface



Storm

**For groundwater and surface water applications where inflow cannot be controlled, twin pump systems complete with a high level alarm and battery backup system should be used, in accordance with BS 8102:2022 and PCA Guidelines. High level alarms and battery backup systems can be purchased to your specification.**

## RECOMMENDED ACCESSORIES

<p><b>AquaSafe Alarm (Sump)</b></p> <p>#22071</p>	<p><b>UPS 3000</b></p> <p>#29000</p>	<p><b>PowerShield 1500</b></p> <p>#37507</p>	<p><b>Battery backup, 24 V</b></p> <p>Please call</p>	<p><b>Inlay access cover</b></p> <p>#18011</p>	<p><b>Additional inlet</b></p> <p>110 mm    50 mm</p> <p>#17010    #17012</p>	<p><b>Discharge reducer kit</b></p> <p>1 1/2" to 1 1/4"    2" to 1 1/4"</p> <p>#8203    #8202</p>
---	--------------------------------------	--	---	--	---	---

All our products can be customised to your requirements. For more information and advice please call our Sales Team on 01442 211554.

# SumpFlushHP 650-1000

## TYPICAL INSTALLATION

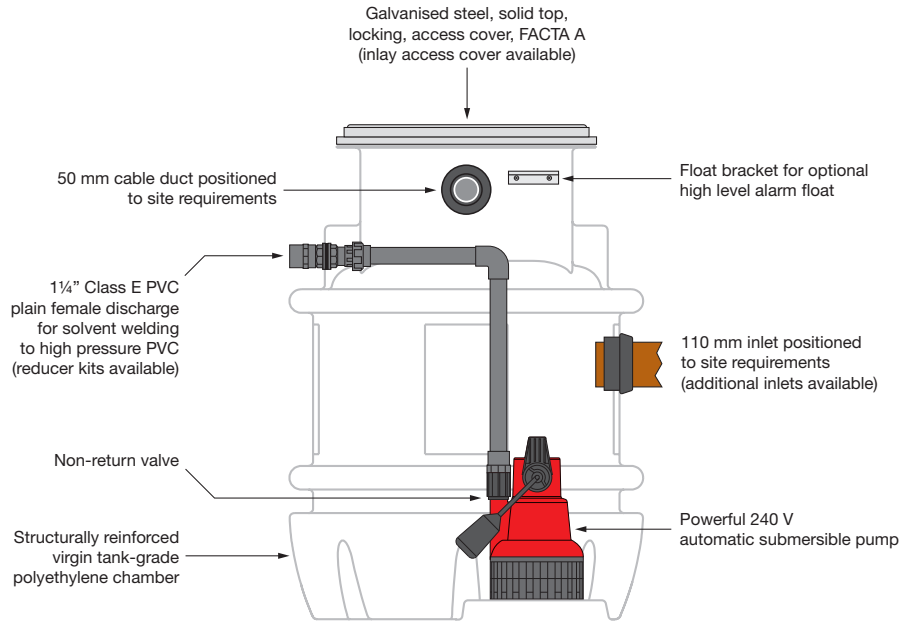

## PUMP SPECIFICATIONS

Number of pumps	One
Impellor type	Vortex
Control	Automatic
Power supply	230 VAC
Rated current	4.9 A
Motor rating (P2)	500 W
Revolutions per min.	2800
Discharge size	1 1/4"
Free passage	10 mm
Max. vertical output	12.5 m
Max. flow rate	4.0 l/s
Max liquid temp.	<40 °C
Cable length	5 m
Weight	6.9 kg

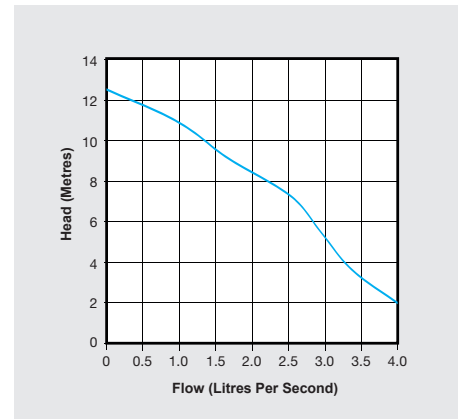

## CHAMBER DIMENSIONS

Shows indicative capacities from lowest inlet invert.

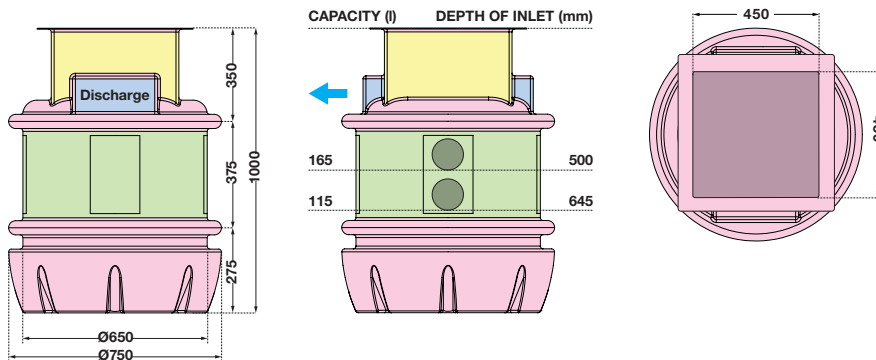

### Permitted connection positions

Discharge only	Inlet location allowed	Cable ducts and vents only	No drilling allowed
----------------	------------------------	----------------------------	---------------------

## CHAMBER SPECIFICATIONS

Internal pipework	1 1/4" OD Class E PVC
Discharge pipework	1 1/4" OD Class E PVC
Lifting eyes	No
Maximum storage capacity	165 litres
Chamber material	Tank-grade polyethylene
Dimensions (Ø x H)	750 x 1000 mm
Clear opening	450 x 450 mm

## ACCESS COVER

Material	Galvanised steel
Cover type	Solid top
Locking	4 screws
Loading	Pedestrian duty FACTA A
Clear opening (H x W)	450 x 450 mm
Dimensions (H x W x D)	515 x 515 x 40 mm

# DELIVERING PUMPED AND DRAINAGE SOLUTIONS FOR OVER 30 YEARS

- Packaged pumping stations**
- Waste water pumping systems**
- Macerators and macerating toilets**
- Floor mounted pumping stations**
- Fat, oil and grease separating systems**
- Rainwater harvesting systems**
- Battery backup systems**
- Adoptable pumping stations**
- Submersible pumps**
- Accessories**



We provide pumped and drainage products and services to the public and private sectors, including residential, commercial, hospitality and retail.

We are proud of the long-term relationships we have built with our clients and partners, delivering cost effective, robust and dependable products and services.

### 12-MONTH GUARANTEE

Your products are protected by a 12-month guarantee. Please refer to our Terms and Conditions at [www.edincare.com](http://www.edincare.com)

### HOW TO ORDER

Order online at [www.edincare.com](http://www.edincare.com)  
 Call Sales on 01442 211554  
 Email [sales@edincare.com](mailto:sales@edincare.com)

### PROJECT SERVICES

- Project design
- Site surveys
- Installations
- Refurbishments

### AFTERSALES SERVICES

- Planned servicing
- Emergency call outs
- Commissioning
- Monitoring

### DRAINAGE SERVICES

- Tankering
- Jetting
- Drainage CCTV
- Surveys
- Cleaning and de-scaling
- Structural repairs
- Excavations
- Root cutting

### [www.edincare.com](http://www.edincare.com)

- Discover our products and services
- Order products online
- Case studies and articles
- Brochures and technical documents

## Protect your property with an Edincare Service Agreement

As with all pumped and drainage systems, regular maintenance is essential to ensure optimum performance and minimal downtime. Our Service Agreements comprises planned preventive maintenance visits at an agreed frequency, we also service other manufacturers' equipment regardless of type, make and age.

- ✓ Validates your building insurance
- ✓ Reduces the risk of failure
- ✓ Increases the life expectancy of your equipment
- ✓ Priority callouts and 24/7 out-of-hours service
- ✓ Reduced rates for emergency call outs
- ✓ Flexible payment options (Direct Debit)



+44 (0)1442 211554  
[info@edincare.com](mailto:info@edincare.com)

[www.edincare.com](http://www.edincare.com)  
[edincarepumps](https://www.linkedin.com/company/edincarepumps)

Unit 8, Heron Business Park, Eastman Way,  
 Hemel Hempstead, Hertfordshire, HP2 7FW

Part of the Edincare Group of Companies [www.edincaregroup.com](http://www.edincaregroup.com)



Our policy is one of continuous product improvement, we reserve the right to change specifications and prices without prior notice. All information is given in good faith. No responsibility can be accepted for errors, omissions or incorrect assumptions. © Omni Pump International Ltd t/a Edincare Pumps & Edincare Drains. All rights reserved.