

Magna150Standard

The Magna150Standard fully automatic packaged pumping station is suitable for pumping foul or grey water to a higher level when gravity drainage is not possible and/or economical to install.

The system provides 150 litre storage capacity, ideal for accepting waste from an extension, outbuilding, basement or similar. The pump's vortex impellor provides reliable and effective pumping of grey water. The compact chamber offers ease of installation for sites with limited space.

The system consists of a polyethylene chamber, locking access cover, internal pipework and fittings, one automatic submersible pump and external compression adaptor.

The Magna150Standard is easy to install as inlets can be positioned to your requirements (inlet information to be supplied at time of order).

KEY FEATURES

- The Magna150Standard pumps grey water without maceration
- Compact 150 litre chamber for limited space installations
- Ideal for an extension, outbuilding, basement or similar
- Variable inlet positions
- A range of alarms and remote alerts are available offering peace of mind
- Easy to install

SPECIFICATIONS

BS EN 12050-3:2015 Wastewater lifting plants for buildings and sites. Lifting plants for limited applications.

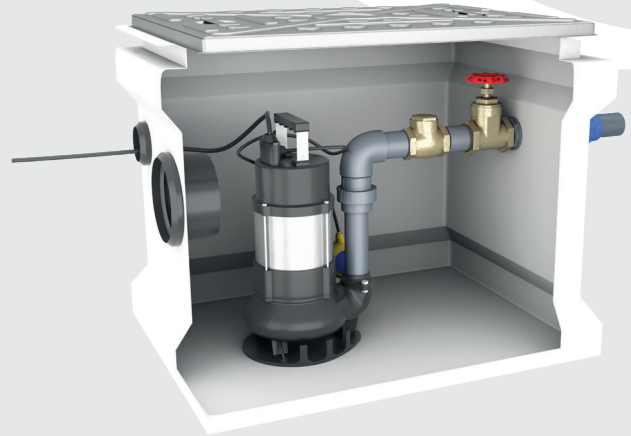

PUMP CURVE

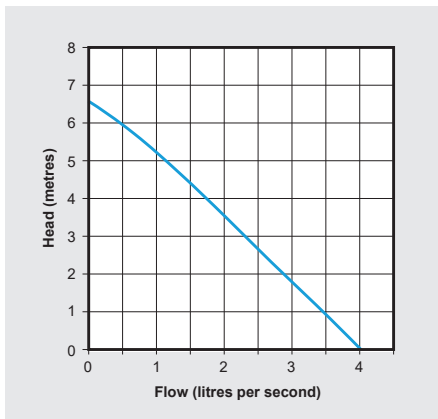

 Do not dispose of wet wipes, sanitary items, nappies or other non-soluble items into the Magna150Standard as these may result in a blockage.

DIMENSIONS (mm)

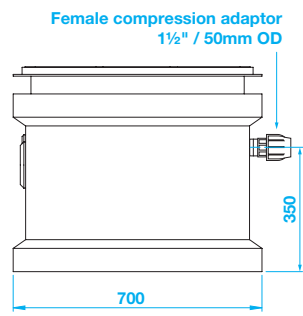
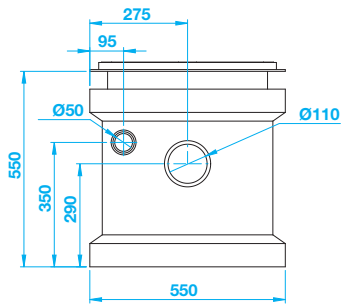

TECHNICAL DATA

CHAMBER	
Discharge pipework	50 mm OD
Lifting eyes	No
Capacity	150 litres
Chamber material	Tank grade polyethylene
Chamber colour	White
Total boxed weight	32 kg

PUMP	
No. of pumps	1
Impellor type	Vortex
Power supply	230V AC
Rated current	1.9 A
Motor rating	250 W
Revolutions per minute	2800
Discharge size	1½"
Free passage	36 mm
Max. vertical output	6.5 m
Max. flow rate	4.0 l/s
Max. liquid temperature	<40°C
Cable length	10 m
Colour	Stainless steel / Black

ACCESS COVER	Length	Width	Depth
Clear opening	600	450	–
including frame	640	490	23

ACCESS COVER	
Material	Galvanised steel
Loading	Solid Top, PP Frame, (Facta A)
Locking	Yes

SUITABLE FOR



WASTE TYPE

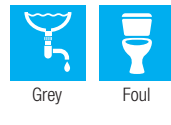

OPTIONAL EXTRAS

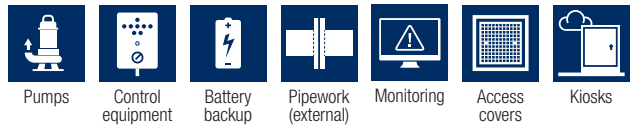

All our products can be customised to your requirements. For more information on this please contact our sales team on 01442 211554.

DELIVERING PUMPED AND DRAINAGE SOLUTIONS FOR OVER 25 YEARS

- Packaged pumping stations
- Waste water pumping systems
- Macerators and macerating toilets
- Floor mounted pumping stations
- Fat, oil and grease separating systems
- Rainwater harvesting systems
- Battery backup systems
- Adoptable pumping stations
- Submersible pumps
- Accessories



We provide pumped and drainage products and services to the public and private sectors, including residential, commercial, hospitality and retail.

We are proud of the long-term relationships we have built with our clients and partners, delivering cost effective, robust and dependable products and services.

12-MONTH GUARANTEE

Your products are protected by a 12-month guarantee. Please refer to our Terms and Conditions at www.edincare.com

HOW TO ORDER

Order online at www.edincare.com
 Call Sales on 01442 211554
 Email sales@edincare.com

PROJECT SERVICES

- Project design
- Site surveys
- Installations
- Refurbishments

AFTERSALES SERVICES

- Planned servicing
- Emergency call outs
- Commissioning
- Monitoring

DRAINAGE SERVICES

- Tankering
- Jetting
- Drainage CCTV
- Surveys
- Cleaning and de-scaling
- Structural repairs
- Excavations
- Root cutting

www.edincare.com

- Discover our products and services
- Order products online
- Case studies and articles
- Brochures and technical documents

Protect your property with an Edincare Service Agreement

As with all pumped and drainage systems, regular maintenance is essential to ensure optimum performance and minimal downtime. Our Service Agreements comprises planned preventive maintenance visits at an agreed frequency, we also service other manufacturers' equipment regardless of type, make and age.

- ✓ Validates your building insurance
- ✓ Reduces the risk of failure
- ✓ Increases the life expectancy of your equipment
- ✓ Priority callouts and 24/7 out-of-hours service
- ✓ Reduced rates for emergency call outs
- ✓ Flexible payment options (Direct Debit)



+44 (0)1442 211554
info@edincare.com

www.edincare.com
[edincarepumps](https://www.linkedin.com/company/edincarepumps)

Unit 8, Heron Business Park, Eastman Way,
 Hemel Hempstead, Hertfordshire, HP2 7FW

Part of the Edincare Group of Companies www.edincaregroup.com



Our policy is one of continuous product improvement, we reserve the right to change specifications and prices without prior notice. All information is given in good faith. No responsibility can be accepted for errors, omissions or incorrect assumptions. © Omni Pump International Ltd t/a Edincare Pumps & Edincare Drains. All rights reserved.