

PowerFlush

The PowerFlush is a fully automatic macerator suitable for pumping waste from a complete bathroom to a higher level when gravity drainage is not possible and/or economical to install.

The system is suitable for installing either at the initial building stage or retro fitting to existing buildings and can accept waste connections from a toilet, basin, shower or bidet.

The PowerFlush incorporates the unique Piranha® cutting system – its razor sharp stainless steel blades act like a pair of rotary scissors to cut up waste items, reducing the chance of a blockage.

The PowerFlush is compact and easy to install, discharging to the right or left.

The system can be fitted with an optional high level alarm.

KEY FEATURES

- Unique 'Piranha' cutting system – part of the Edincare 'FullCut' range
- Designed to accept waste from a full bathroom suite including toilet, basin, shower and bidet
- Inlet and discharge pipe work can be fitted to either side of the unit for maximum versatility
- Optional high level alarm can be used to transmit faults to BMS



INSTALLATION EXAMPLE

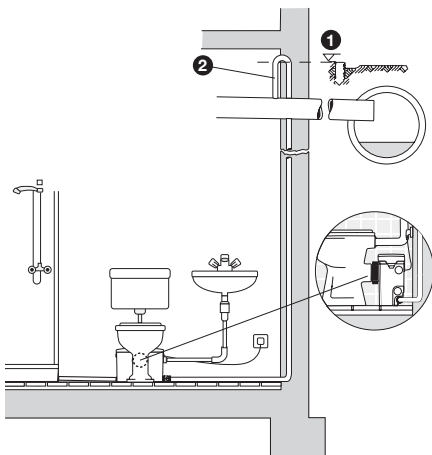

1. Backwash level
2. Backwash loop with base above the backwash level.

DIMENSIONS (mm)

Product	Length	Width	Height
PowerFlush	414	197	287

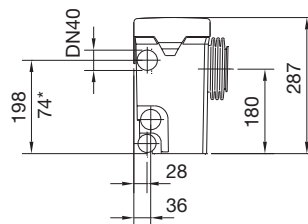
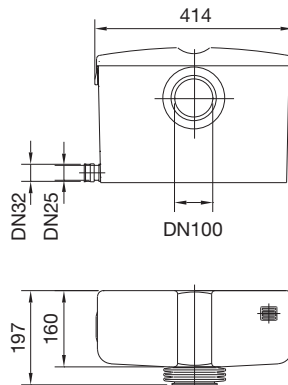

TECHNICAL DATA

PowerFlush	
Power supply	230V AC
Rated current	4.7A
Motor rating	1100W
Frequency	50Hz
Revolutions per min.	2900rpm
Max vertical output	7m
Max horizontal output	50m
Horizontal fall	1:200
Max flow rate	96 l/m
Max liquid temp.	<60°C intermittent
Discharge size	32mm
Cable length	2.2m
Weight	9kg
Colour	White

PUMP CURVE

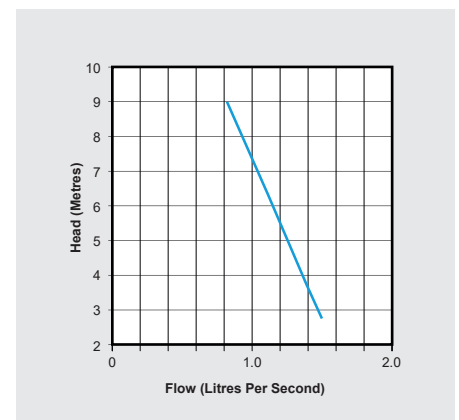

SUITABLE FOR

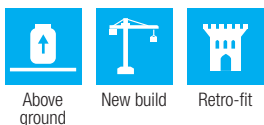

WASTE TYPE



OPTIONAL EXTRAS



All our products can be customised to your requirements. For more information on this please contact our sales team on 01442 211554.

DELIVERING PUMPED AND DRAINAGE SOLUTIONS FOR OVER 25 YEARS

- Packaged pumping stations
- Waste water pumping systems
- Macerators and macerating toilets
- Floor mounted pumping stations
- Fat, oil and grease separating systems
- Rainwater harvesting systems
- Battery backup systems
- Adoptable pumping stations
- Submersible pumps
- Accessories



We provide pumped and drainage products and services to the public and private sectors, including residential, commercial, hospitality and retail.

We are proud of the long-term relationships we have built with our clients and partners, delivering cost effective, robust and dependable products and services.

12-MONTH GUARANTEE

Your products are protected by a 12-month guarantee. Please refer to our Terms and Conditions at www.edincare.com

HOW TO ORDER

Order online at www.edincare.com
 Call Sales on 01442 211554
 Email sales@edincare.com

PROJECT SERVICES

- Project design
- Site surveys
- Installations
- Refurbishments

AFTERSALES SERVICES

- Planned servicing
- Emergency call outs
- Commissioning
- Monitoring

DRAINAGE SERVICES

- Tankering
- Jetting
- Drainage CCTV
- Surveys
- Cleaning and de-scaling
- Structural repairs
- Excavations
- Root cutting

www.edincare.com

- Discover our products and services
- Order products online
- Case studies and articles
- Brochures and technical documents

Protect your property with an Edincare Service Agreement

As with all pumped and drainage systems, regular maintenance is essential to ensure optimum performance and minimal downtime. Our Service Agreements comprises planned preventive maintenance visits at an agreed frequency, we also service other manufacturers' equipment regardless of type, make and age.

- ✓ Validates your building insurance
- ✓ Reduces the risk of failure
- ✓ Increases the life expectancy of your equipment
- ✓ Priority callouts and 24/7 out-of-hours service
- ✓ Reduced rates for emergency call outs
- ✓ Flexible payment options (Direct Debit)



+44 (0)1442 211554
info@edincare.com

www.edincare.com
[edincarepumps](https://www.linkedin.com/company/edincarepumps)

Unit 8, Heron Business Park, Eastman Way,
 Hemel Hempstead, Hertfordshire, HP2 7FW

Part of the Edincare Group of Companies www.edincaregroup.com



Our policy is one of continuous product improvement, we reserve the right to change specifications and prices without prior notice. All information is given in good faith. No responsibility can be accepted for errors, omissions or incorrect assumptions. © Omni Pump International Ltd t/a Edincare Pumps & Edincare Drains. All rights reserved.