



COMPANY OVERVIEW

DELIVERING PUMPED SOLUTIONS



RESIDENTIAL



PUBLIC
SECTOR



COMMERCIAL



HOSPITALITY
& RETAIL



Edincare Pumps has been established for over 25 years specialising in the manufacture, project design, sale, commission, service and repair of pumped solutions.

We operate from our 25,000 sq. ft office, production, warehouse and training facility based in Hemel Hempstead, Hertfordshire. Our experienced team work with customers, suppliers and partners to deliver the very best service and highest quality products.



PRODUCTS

We offer a comprehensive range of products, that includes:

- Packaged pumping stations
- Waste water pumping systems
- Macerators and macerating toilets
- Floor mounted pumping stations
- Fat, oil and grease separator systems
- Rainwater harvesting systems
- Battery backup systems
- Adoptable pumping stations

All Edincare products are manufactured to exacting standards and following our ISO9001 quality management system allowing us to deliver exceptional equipment and service.

PRODUCTION & WAREHOUSE

From our extensive warehouse and production facility based in Hemel Hempstead, Hertfordshire we hold large stocks of spare parts and preassembled products enabling us to provide a rapid response to all orders.

DELIVERY

We offer a wide range of delivery options (next day, same day, before 10.30am, before 12.00noon). Our dedicated fleet of delivery vehicles, standard vans and flatbed vehicles complete with crane are used to meet all delivery requirements.

TRAINING

We offer in house training to your sales and technical teams. We have recently opened our new training facility. This is a practical environment providing you the opportunity to see our product range and be specifically trained on all technical aspects such as specification, installation and ongoing maintenance. We cover a wide range of technical topics, including electrical connections, pipework types, civil works, controls, design criteria etc. Training can also be organised at your premises if required.



WEBSITE

The website includes extensive product information to help you navigate Edincare's complete range of pumped solutions. Product specification, technical data and application case studies work together to provide a detailed overview of Edincare's capabilities across a wide range of sectors, including Residential, Commercial, Hospitality & Retail and Public Sectors.

You can also stay informed with the latest news of the company, and the whole pumps industry. The News section features our latest announcements and new product launches, and pieces from our experts, about the industry.

TECHNICAL SUPPORT

We pride ourselves on the level of technical support offered, delivered via telephone, online and onsite to assist you through product selection, installation and ongoing maintenance.

Simply contact us and one of our technical representatives will gladly assist you.

HEALTH & SAFETY

Edincare Pumps is registered with SafeContractor, CHAS, British Safety Council, Constructionline, ISO9001, NICEIC, FORS, PCA and the Basement Waterproofing Association demonstrating our commitment to both Health and Safety and our quality of workmanship.

OUR PARTNERS

We are proud to work with many leading pump manufacturers, who are recognised for their high quality and long-lasting, durable pumps and associated equipment.



We offer a comprehensive range of Project and Aftersales Services, that includes; Site Surveys, Project Design, Installations, Refurbishments, Planned Servicing, Emergency Call Outs, Commissioning, Monitoring and Tankering & Jetting.

With Nationwide coverage and service vehicles located throughout the UK, we are able to provide a rapid response to your Project and Aftersales requirements.



PROJECT SERVICES

Site Surveys

Our experienced Project Coordinators will survey your site to fully assess the specific requirements of your pumping scheme. We will inspect mechanically, electrically and operationally, assessing the condition of the chamber/s, pump/s, associated pipework, valves, control philosophy and the control panel, and provide a full report of our findings, with proposed recommendations and quotation.

Project Design

With our extensive technical knowledge of pumped systems, our Project Team will ensure all aspects of your application are considered. We offer a full in-house design service working from either site drawings, or where appropriate, undertake no obligation on site surveys.

Installations

Our services range from the installation of new control equipment, submersible pumps through to full pump station refurbishments. Our Engineers are fully trained in all aspects of working with pumped systems, as well as being specifically trained in the use of gas detection equipment, confined space entry procedures and all relevant health and safety legislation.

Refurbishments

Our team of experienced Engineers can undertake refurbishments to existing pump systems, ensuring they provide ongoing efficient and effective operation. Whether you have an existing pump system that needs a full refurbishment or just some maintenance due to parts or mechanical failure, our Project Team can attend site to assess your requirements.





AFTERSALES SERVICES

Planned Servicing

As with all systems of this nature, regular maintenance is essential to ensure the system operates at its optimum level. Our Service Agreements consist of planned preventive maintenance visits at an agreed frequency, and we also service other manufacturers' pump equipment regardless of type, make and age.

Emergency Call Outs

We offer support 24 hours a day, 7 days a week, nationwide to help you with any pump system emergency. With our own fleet of vehicles and in-house tankering and jetting services throughout the UK, we can respond to emergency call outs quickly.

Commissioning

All commissioning works are carried out by our fully qualified Service Engineers. Upon successful completion of the works you will be provided with a detailed report of the works undertaken along with a commissioning certificate confirming the equipment has been tested in accordance with our operating guidelines.

Monitoring

Our monitoring systems are suitable for where the possibility of pump failure through either a pump fault or loss of mains power would be catastrophic. Whether you are at home or away, you and your key holders will receive alerts if a fault condition occurs, so that you can manage the condition immediately.

Tankering & Jetting

We offer tankering and jetting services throughout the UK. We provide a fast response to quickly and efficiently manage all drainage requirements, that include; tankering and jetting for pump station chambers/sumps, drains, drainage channels etc.

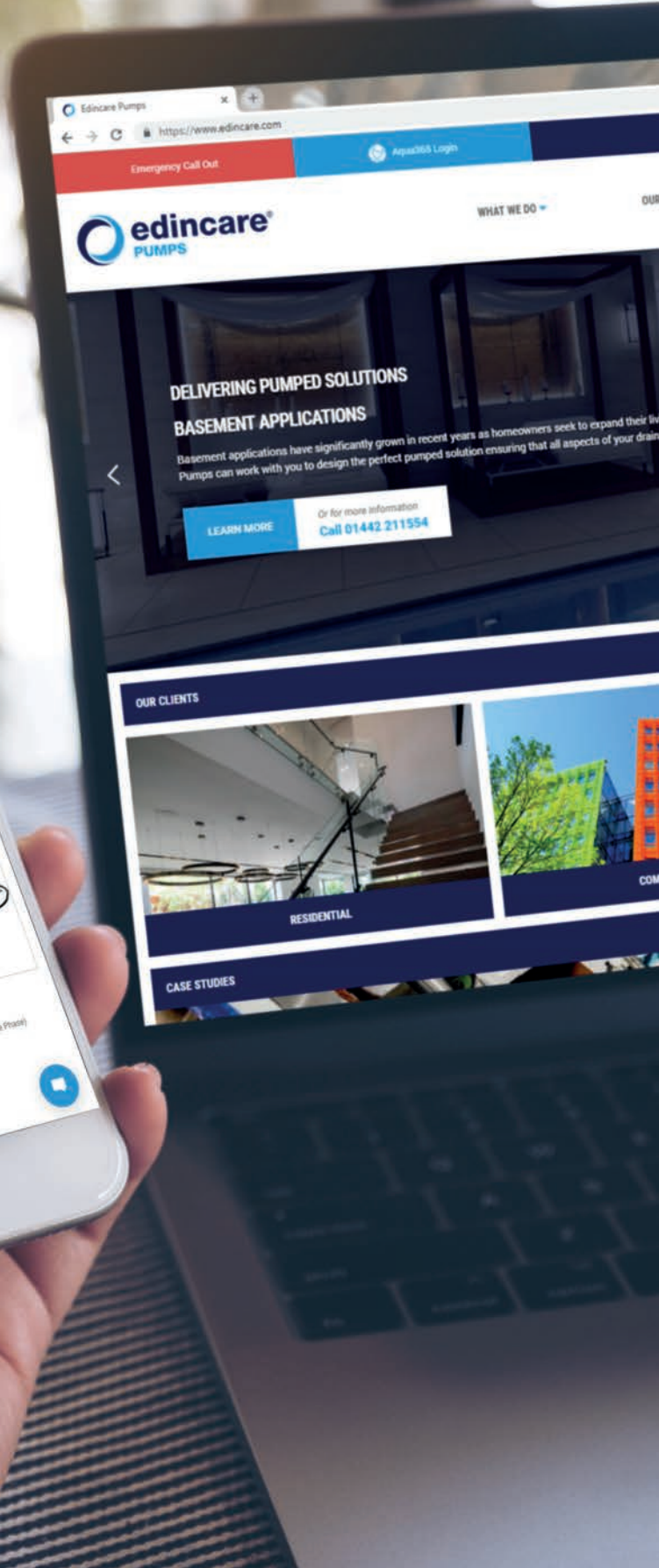



For more information on our products and services visit www.edincare.com



Retail Superstore

CLIENT

Supermarket Retailer

SECTOR

Hospitality & Retail

PROJECT TYPE

Supply, Install & Commission

PRODUCTS USED

AutoFlushSSTwin & ProTrapAuto

ONSITE DURATION

1 day

LOCATION

London

REQUIREMENT

A grease trap and pumping station were required for a rotisserie oven and kitchen facility at a large supermarket in London. The grease trap would be required to effectively remove large volumes of grease with a low flow of water. The system would need to be quick and hygienic to be maintained for kitchen staff.





METHOD

- A ProTrapAuto grease trap and AutoFlushSSTwin waste water pumping system were installed within the kitchen.
- The ProTrapAuto effectively removes grease and food particles into separate collection containers for easy disposal by kitchen staff.
- After removal of the grease and food particles, waste water from the grease trap discharges into the AutoFlushSSTwin for pumping into a soil pipe in the ceiling.

RESULT

- The fully-automatic ProTrapAuto removes fat, oil and grease before they solidify and de-waters solid food waste, each into separate containers for appropriate disposal by kitchen staff. This greatly simplifies maintenance compared to static grease traps which require regular emptying and cleaning.
- Constructed from high-grade stainless steel both units are robust, easy to clean and hygienic making them ideally suited to busy kitchen environments.

FOCUS ON

AUTOMATIC VERSUS STATIC GREASE TRAPS

Grease traps solidify and capture fat, oil and grease (FOG) from waste water before sewer discharge.

Static traps are simple chambers which require regular opening for manual removal of waste and cleaning. This can be time-consuming and unhygienic.

Automatic grease traps are self-cleaning systems that actively collect and separate FOG making maintenance simple, quick and hygienic for busy kitchen staff.

The ProTrapAuto is an exceptional automatic grease trap with a versatility that makes it the ideal choice for any food preparation environment.



Student Accommodation

CLIENT
Student Accommodation

SECTOR
Residential

PROJECT TYPE
Supply, Install & Commission

PRODUCTS USED
MagnaGrand IP & Mixer

ONSITE DURATION
8 days

LOCATION
London

REQUIREMENT

We were asked to specify twin foul water pumps capable of 6l/s at a 12m head due to a two storey basement excavation. The pumps required large solids clearance due to the nature of the multi-occupancy dwelling. A mixer would be needed to prevent the build-up of floating fats and solids. We were asked to plan the route through the two storey basement for the rising main to run.



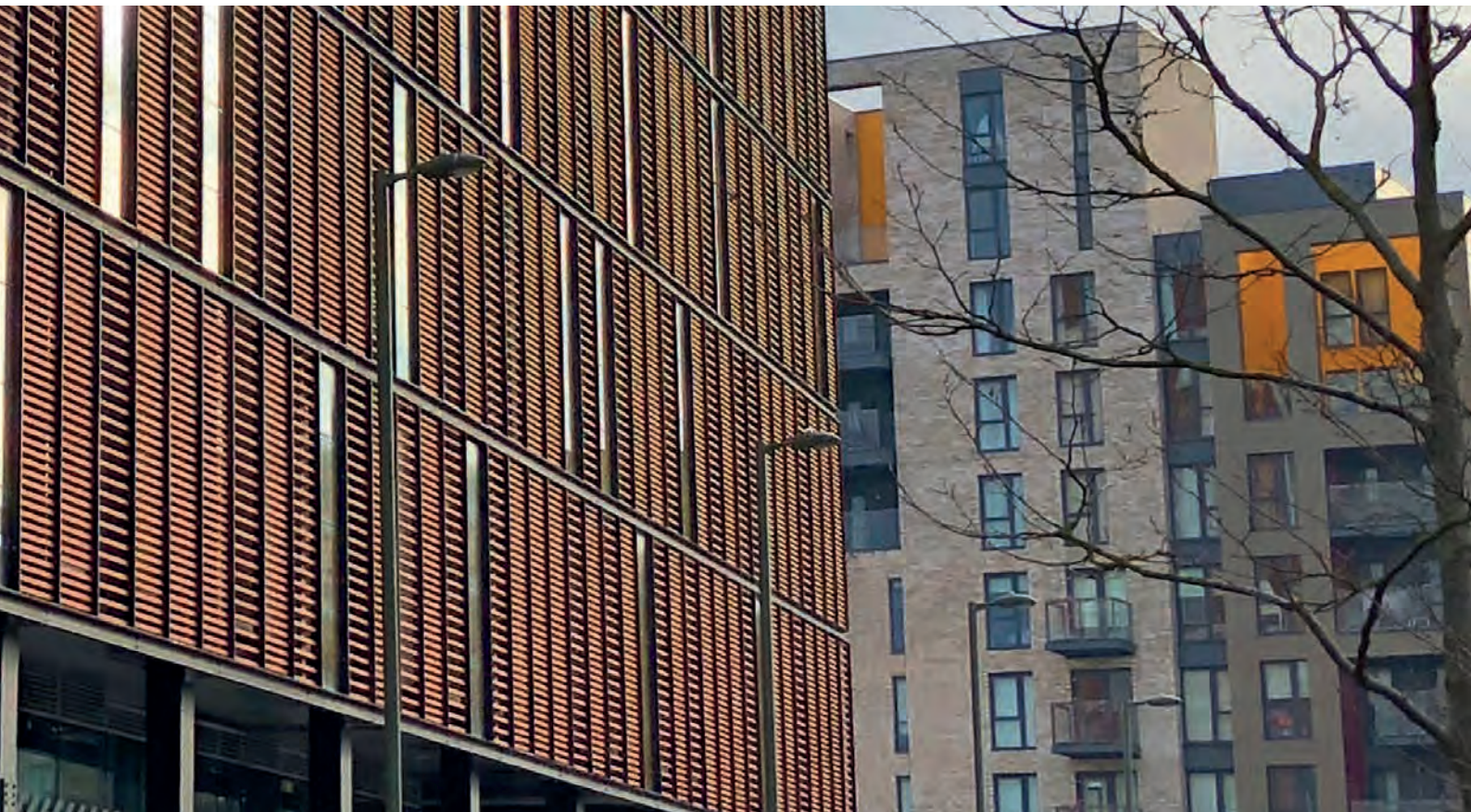

METHOD

- Twin guide rail mounted pumps with an 80mm solids clearance were installed into a concrete sump 10m long, 2.4m wide and 3.5m deep.
- A horizontal mixer was fitted into the sump in a separate location to operate in conjunction with the pumps, operating just before the pump activates.
- A 110mm HDPE rising main was supplied with electrofusion fittings and anti-vibration couplings.

RESULT

- The pumps have an 80mm clear passage through the body of the pump, reducing the chances of blockages.
- The duty / standby set up means each pump is capable of the necessary flow rate, in case one fails for any reason.
- A mixer circulates the water throughout the sump so that floating solids are mixed and pumped away.
- The pumping station service interval has been agreed with the maintenance team.
- The comprehensive control panel allows for BMS monitoring and a telemetric system for offsite monitoring.

FOCUS ON

THE BENEFITS OF A MIXER

Installing a mixer in the sump prevents the build up of fat and other floating solids.

Without a mixer, these deposits can build up on the floats and in the upper water column. This can interfere with the float switches operation and degrade the connecting electrical cable.



Government Agency

CLIENT

Police Force

SECTOR

Public Sector

PROJECT TYPE

Supply, Install & Commission

PRODUCTS USED

MagnaPro SS & MagnaPro IP

ONSITE DURATION

10 days

LOCATION

London

REQUIREMENT

We were asked to design, install and commission three stainless steel floor mounted pumping stations and two underground pump sets. The pump sets were to be installed within pre-existing concrete sumps. We would have to carry out all work in a confined basement space.

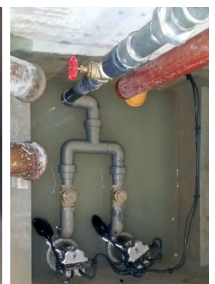
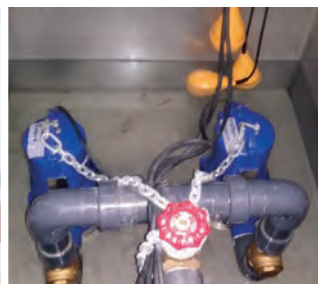



METHOD

- Three MagnaPro SS floor mounted pumping stations were specified and installed.
- Two MagnaPro IP pumpsets were installed into prepared concrete sumps.
- All connections to inlet and discharge pipework were made to our pumping stations.
- The client supplied the inlet and discharge pipework within 1m of our pumping station for us to connect and commission.

RESULT

- One piece stainless steel tanks are much more robust than GRP chambers, and can be carefully designed to fit on site.
- Quick and easy installation compared with sectional tanks which have to be built on site.
- Installing pumps directly into pre-cast concrete chambers avoids the need for a packaged pumping station.
- Regular maintenance of these units is essential.
- The high level alarm and BMS connection will provide early notification of a system failure to allow facilities management to take action quickly.

FOCUS ON

ULTRASONIC WATER LEVEL CONTROLS

Ultrasonic sensors are a reliable and versatile alternative to floats and probes.

The water level for stop, start, assist and high level are programmed into the ultrasonic controller.

This method of level control is contactless so it is not affected by the condition of the pump station.

Float switches can be snagged on floating debris and fat which can create a crust on top of the water in a foul water chamber.

CHAMBERS

7 DIAMETERS

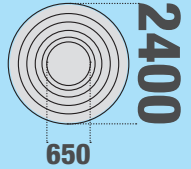

2400

650

4m

13 DEPTHS

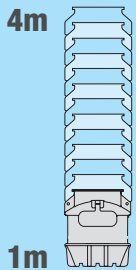

1m

CAPACITIES
165l → 15,385l

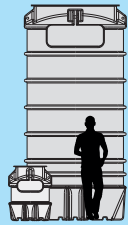

PUMPS

SINGLE OR **DUAL**



**MACERATOR
VORTEX
GRINDER**



240V **415V**

+ **=**

PIPEWORK

9 DIAMETERS
32mm → DN150

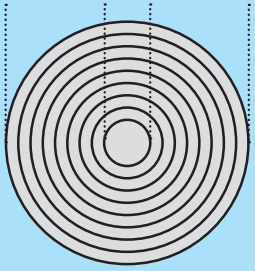

**PVC
GALVANISED STEEL
DUCTILE IRON
STAINLESS STEEL**

CONTROLS

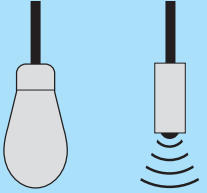

**PROBES
FLOATS
ULTRASONICS**

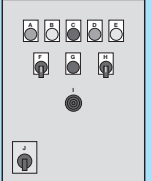

**CONTROL
PANELS**



10
com



0,000+
binations

Your pump station Your Way

The MagnaPro™ is a range of fully automatic packaged pumping stations, suitable for pumping ground, surface, storm and foul water to a higher level when gravity drainage is not possible or uneconomical to install.

Our new range has been engineered from the ground up incorporating a wide range of unique features, ensuring the product adheres with all current design standards and beyond. Our packaged pumping station range allows bespoke selection of chamber size, pump type and controls to meet your specific site requirements.

**For more information call
Edincare Pumps today on**

01442 211554



High Street Food Retailer

CLIENT

Sandwich / Hot Food Outlet

SECTOR

Hospitality & Retail

PROJECT TYPE

Specify, Supply & Installation

PRODUCTS USED

ProTrap Auto

ONSITE DURATION

1 day

LOCATION

London

REQUIREMENT

We were asked to retrofit a grease trap into an existing commercial kitchen. We had to avoid daytime kitchen closures. Careful attention to pipework falls were needed to prevent sinks backing-up.





METHOD

- An overnight installation was executed.
- A full site survey was carried out to ensure installation would go seamlessly.
- We specified an active grease trap, rather than a static grease trap to increase the level of FOG removal.
- We fully wet tested the kitchen to maximum capacity prior to opening to ensure there were no issues.

RESULT

- An active grease trap can be emptied and maintained daily by kitchen staff.
- A correctly maintained active grease trap is less likely to suffer from nuisance smells and odours.
- An active grease trap such as a ProTrap Auto also removes food particles to reduce blockages.
- An after-hours installation ensured no disruption to business.
- This solution reduces the need for costly drain rodding and the risk of possible kitchen closure which could affect business.

FOCUS ON

TENANT RESPONSIBILITY FOR DRAINAGE PROTECTION

Commercial landlords are increasingly requiring tenants to install drainage protection through FOG removal. This is to protect their property and ensure that any incidents that might occur do not affect neighbouring properties or incur costly bills.



Domestic Residential Property

CLIENT

New Build Contractor

SECTOR

Residential

PROJECT TYPE

Supply, Install & Commission

PRODUCTS USED

MagnaPro & SumpFlushProTwin

ONSITE DURATION

15 days

LOCATION

London

REQUIREMENT

We were asked to design, supply and commission 18 packaged pumping stations for the basements of nine adjacent new build houses. Each property was to have their own separate foul water and surface water pumping station.





METHOD

- Drawings were sent to the Projects Team and a site meeting set up to discuss the requirements.
- Foul water was to be pumped from the basements and surface water was to be pumped from small external lightwells.
- 1000mm diameter x 1750mm deep chambers were selected from our MagnaPro range for the foul water and SumpFlushProTwins were selected for the surface water.
- In addition to this we were requested to run all discharge pipework from the chambers up to the gravity connection at high level.

RESULT

- 18 pumping stations were supplied.
- Discharge pipework connections were made using electrofusion fittings to the above basement slab level to allow the concrete structural slab to be poured.
- We returned after the basement structure had been completed to connect this pipework to the gravity drainage.
- Finally, all 18 pumping stations were commissioned.

FOCUS ON

AFTERSALES SUPPORT

After completing all of the pipework and commissioning works, we have installed telemetric monitoring from our Aqua365 range.

We have a service contract in place with the managing agent which will remain in place until each property is sold.

We supplied comprehensive operation and maintenance manuals, including servicing guidelines to be handed over to the new owners.

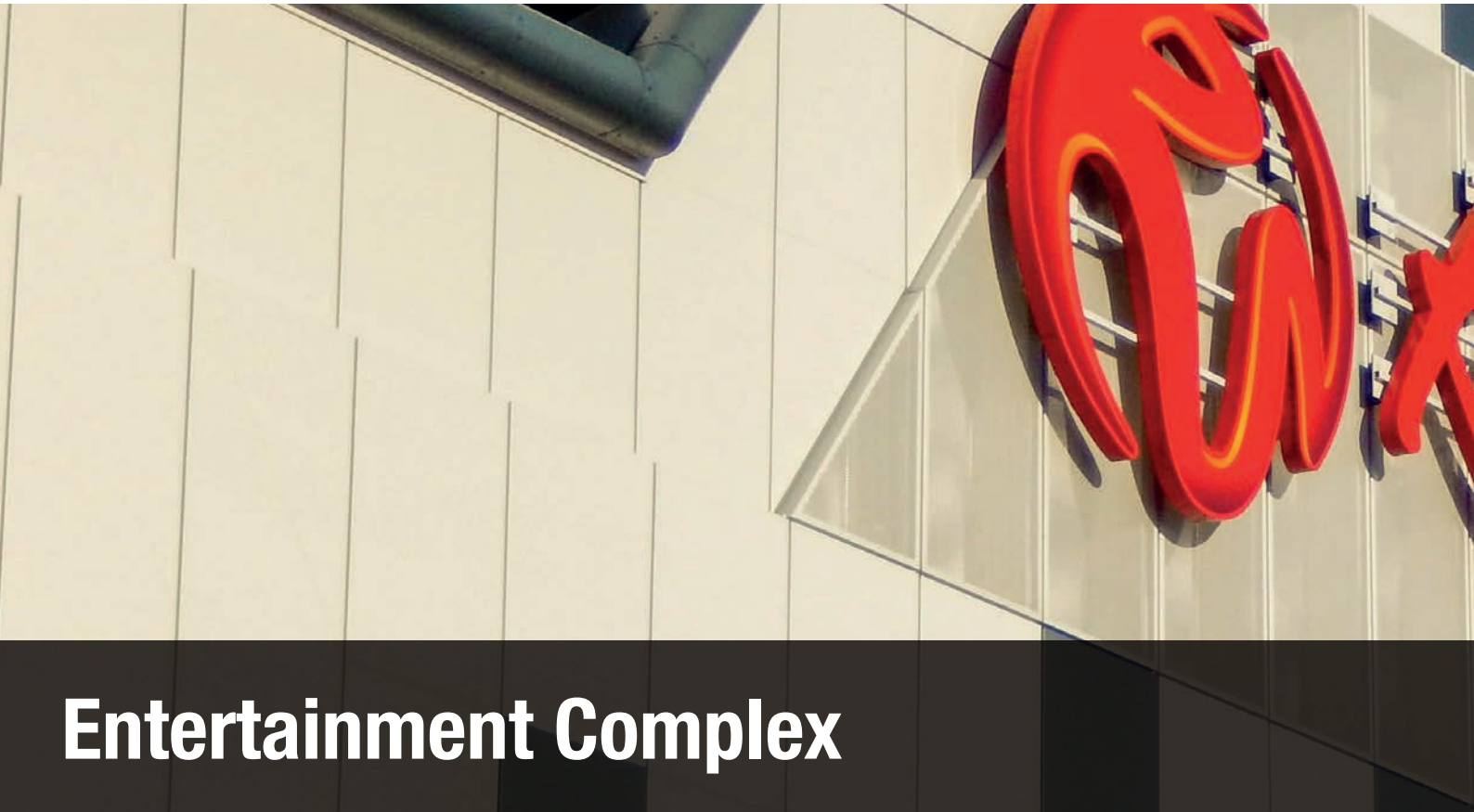

Entertainment Complex

CLIENT

Shopping Centre

SECTOR

Hospitality & Retail

PROJECT TYPE

Refurbishment

PRODUCTS USED

Ductile Iron Pipework

ONSITE DURATION

2 days

LOCATION

Birmingham

REQUIREMENT

We were asked to upgrade the internal PVC pipework inside the pumping station to ductile iron pipework. A bespoke manifold was required to interface the new internal pipework with the rising main. All work would need to be carried out on a live pumping chamber.





METHOD

- The chamber was accessed using a two man confined space entry team to measure up the existing pipework.
- Due to a ductile iron pipework manifold being much wider than a PVC manifold, a custom steel manifold was built specifically for this chamber.
- New risers, non-return valves, manifold and gate valve were installed within the chamber.

RESULT

- Ductile iron pipe has more than 13 times the impact strength, nine times the tensile strength and four times the burst strength of PVC pipe and unlike PVC pipe, it can handle stress.
- Ball type non-return valves were installed which are less likely to become fouled with rag and operate quietly.
- The pumping station is now in excellent working order.
- Future maintenance will be easier as the pipework is flanged and bolted together.

FOCUS ON

WORKING ON A LIVE CHAMBER

Working in a live chamber creates its own challenges. Planning the operation so that one pump is always online or contracting of a suction tanker to remove waste, adds further complication to the confined entry.





Pumped basement solutions

Over the course of the past decade the basement sector has grown significantly.

This has resulted in more complex projects involving multiple basement levels with the introduction of bathrooms, utility rooms, swimming pools, outdoor spaces and a variety of waterproofing measures.

We offer a wide range of pumped solutions, including ground, surface and foul water pump stations along with optional extras that include high level alarms and battery back-ups, to name a few.

**For more information call
Edincare Pumps today on**

01442 211554



Residential Basement Development

CLIENT

Ground Worker

SECTOR

Residential

PROJECT TYPE

Supply, Install & Commission

PRODUCTS USED

MagnaPro

ONSITE DURATION

5 days

LOCATION

London

REQUIREMENT

We were asked to design, supply and commission four packaged pumping stations for the basements of two adjacent new build houses. Each property was to have their own separate foul water and storm water pumping station.





METHOD

- Drawings were sent to the Projects Team. These were assessed and any missing information requested from the client.
- 1500mm diameter x 3000mm deep chambers were selected from our MagnaPro range.
- DN80 pumps with an 80mm solids handling were specified for reliability.
- A site consultation was carried out to talk through the design of the systems and also the installation requirements.
- The pumping stations were installed within oversized waterproof reinforced concrete sumps.
- After installation the pumps were tested and commissioned.

RESULT

- The customer provided a complete solution for the client's needs.
- Assistance was offered at every stage of the complex installation due to the depth of the basements and a high water table.
- After commissioning the pumps the Project Manager attended site and carried out a multipoint check of the works to ensure they were completed to his satisfaction.

FOCUS ON

DEWATERING BASEMENT EXCAVATIONS

When the basement dig is close to a local watercourse, groundwater can be present relatively high in the ground. Dewatering this excavation can be very challenging. Boreholes need to be dug across the site and temporary dewatering carried out to allow the waterproof structural slab to be poured. In addition to supplying the packaged pumping stations Edincare also supplied the pumps for the dewatering.



Collection of Luxury Homes

CLIENT
London Based Property Developer

SECTOR
Residential

PROJECT TYPE
Specify, Supply & Install

PRODUCTS USED
MagnaGrand IP

ONSITE DURATION
60 days

LOCATION
London

REQUIREMENT

We were asked to plan, specify and install a system of pumping stations to remove foul, storm and ground water separately from the basement of one of London’s largest residential excavations. The pumps would need to be capable of pumping over a 9m head due to the three storey excavation. We would be part of an integrated team of contractors working systematically through the different phases of the build programme.





METHOD

- Chose specialised pumps to perform to the high specification.
- A total of 23 pump stations were installed: 11 groundwater, 6 foul, 4 storm water and 2 lift pit pump stations.
- Vortex impellers were specified to reduce the risk of blocking.
- We worked in close coordination with the developer to install the pumps following each phase of the development.

RESULT

- Throughout the project we have built a close relationship with the client and his team.
- Highly reliable systems have been supplied with a long lifespan.
- All pump stations will report to the building management system for continuous and straightforward monitoring.
- Ongoing maintenance is important to ensure the reliability and longevity of the pumping stations.
- A comprehensive service agreement has been taken out with quarterly services agreed.

FOCUS ON

THE TEAM DELIVERS ON A PRESTIGIOUS AND COMPLEX PROJECT

Successful fulfilment of this contract on 'Billionaire's Row' in London demonstrated again how Edincare Pumps' whole team can offer top quality products and services to prestigious projects.

Our projects team designed and specified a high quality system to match the exacting brief.

Our on site engineers worked closely with the client and other contractors to integrate into the complex build programme.

The rest of Billionaire's Row is undergoing continual redevelopment and Edincare is negotiating further work with this and other contractors.



Private Residence

CLIENT
Private Customer

SECTOR
Residential

PROJECT TYPE
Refurbishment

PRODUCTS USED
MagnaGrand IP

ONSITE DURATION
1 day

LOCATION
London

REQUIREMENT

We were asked to survey an existing pumping station and to carry out a full refurbishment. Confined space entry installation was required. Due to the system being live, we were required to carry out the installation within one day.





METHOD

- We carried out a site survey and produced a report for the client. This included a quotation to replace the internal galvanised steel pipework and guide rails.
- Scheduled a period when the facilities would not be used and arranged for a suction tanker to clear and wash down the wet well.
- We cut out the existing corroded pipework and replaced it with new galvanised steel pipework of the same diameter and configuration.

RESULT

- Galvanised steel pipework offers a long life span.
- The float switches were also changed as a precautionary measure.
- Following our inspection, we judged that the existing pumps did not need replacing as they were relatively new.
- Changing the non-return valves, which showed signs of failure, helped prevent costly pump replacement in the future as any backflow / recirculation will be prevented.

FOCUS ON

REGULAR CLEANING OF THE CHAMBER PREVENTS PROBLEMS

Regular clearing out of the wet well using a suction tanker removes silt and debris, as well as floating wet wipes.

Fat can form a biscuit on top of the water. This can interfere with the float switch operation.



DASHBOARD

CONNECTION STATUS

LAN OK

GPBS OK

WIFI OK

POWER STATUS

POWER OK

AQUA 365 OK

EQUIPMENT

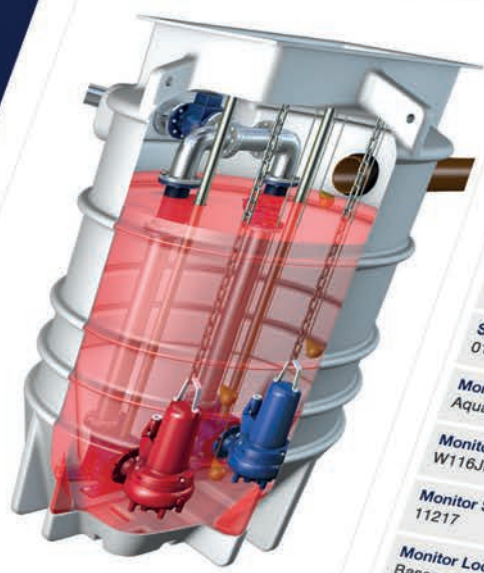

DETAILS

Site Contact
Kate Lewis

Site Address
Unit 8, Heron Business Park
Eastman Way
Hemel Hempstead

Site Postcode
HP2 7FW

Site Email
info@edincare.com

Site Telephone
01442 211554

Monitor Name
Aqua365

Monitor Serial no.
W116JPA0078

Monitor SO no.
11217

Monitor Location (level)
Basement Level -1

Monitor Sold Date
03-07-2017

Monitor Activation Date
04-07-2017

SYSTEM LOGS

TIMESTAMP	CONDITION	DURATION
2017-07-03 14:00:03	Power restored	
2017-07-03 13:59:43	Power failure	00:00:20
2017-07-03 13:59:03	Pump 1 restored	
2017-07-03 13:58:23	Pump 1 tripped	00:47:16
2017-07-03 13:57:43	Connection restored	
2017-07-03 13:57:23	Pump 2 restored	00:00:20
2017-07-03 13:56:43	Connection failure	01:04:16
2017-07-03 13:56:03	Pump 2 tripped	
2017-07-03 13:55:23	High level restored	00:02:20
2017-07-03 13:55:03	Power restored	
2017-07-03 13:54:43	Power failure	00:00:20
2017-07-03 13:54:23	High level alarm	



Aqua365™ Monitor 

Looking for peace of mind? Look no further

The Aqua365 Monitor has been designed to put you in control of your pump system.

Using our Aqua365 online portal you can view the current condition of your pump system real time from any online device.

Whether you are at home or away, you and your keyholders will receive alerts via email and SMS if a fault condition occurs, so that you can manage the condition immediately.

**For more information call
Edincare Pumps today on**

01442 211554



Place of Worship

CLIENT

Mosque

SECTOR

Public Sector

PROJECT TYPE

Refurbishment

PRODUCTS USED

Replacement Parts

ONSITE DURATION

1 day

LOCATION

London

REQUIREMENT

We were asked to service a very deep (6m) pumping station at a London mosque. Repairs to the rising main discharge pipework were needed. Due to the dimensions of the chamber, confined space entry using man riding equipment, and suitably qualified members of staff were required.





METHOD

- A tripod was erected at the top of the chamber with man riding winch and fall arrest block.
- Gas conditions were continuously monitored inside the chamber whilst engineers were inside.
- A full service of the pumping station was carried out, which involved cleaning the float switches and pumps, checking the float switch levels, operation and alarms.
- The compression type fitting was replaced with an electrofusion fitting on the discharge pipework.

RESULT

- Regular maintenance of the pumping station allows qualified people to assess its condition. In this case, a leak in the discharge was identified and repaired before total failure. If the pipework had failed, water would have recirculated in the chamber, the high level alarm would have sounded and an emergency call out would have been required.
- Our customer has entered into a 5-year service agreement term. We offer a significant discount for customers who sign up for a longer term which protects the customer from price increases, as the price is fixed for the duration of the service agreement.

FOCUS ON

ELECTROFUSION FITTINGS

Electrofusion is a method of precisely joining medium-density polyethylene (MDPE) and high-density polyethylene (HDPE) pipes using built-in low voltage heating elements within the fitting to weld the joint.

The inner surface of the fitting and the outer surface of the pipe melt, which cools to produce a very homogenous, reliable and long-lasting joint.

Installation is simple and computer control ensures consistent quality.

Pipes joined by electrofusion fittings are suitable for all applications from potable water to waste water.



Leading Preparatory School

CLIENT

School

SECTOR

Public Sector

PROJECT TYPE

Regular Servicing

PRODUCTS USED

Replacement Parts

ONSITE DURATION

1 day

LOCATION

London

REQUIREMENT

We were asked to include a rainwater harvester not supplied by ourselves onto an existing service agreement. The rainwater harvester was only brought to our attention after it failed and had switched over to mains water top up. No maintenance had been carried out for some time. In order to provide ongoing support for this system we needed to identify its design, pumps, filter type and controls.





METHOD

- A full site survey was carried out prior to commencing the job.
- The equipment was identified, and subsequently, we discovered there was an additional overflow pump in the underground chamber which fortunately had not failed.
- A replacement supply pump was quoted.
- All the details were reported to the office, and now all the equipment is listed on our service agreement for its regular maintenance.

RESULT

- Regular maintenance of the rainwater harvester allows qualified people to assess the condition of the equipment.
- A large public sector building being forced to run their toilets off mains water for any period of time would lead to an increased water bill.
- Now we are aware of the systems existence, we will monitor and service this system in line with the two pumping stations we already service on this site.

FOCUS ON

STEPPING IN TO HELP

We are often asked by existing customers to service equipment which we did not install and have not previously maintained.

Sometimes the customer simply does not know the equipment exists, because it is hidden underground. Or, they do not know we can service this type of equipment.

Residential Apartments

CLIENT

Large Design, Build & Installation Company

SECTOR

Residential

PROJECT TYPE

Supply, Install & Commission

PRODUCTS USED

MagnaGrand (Dry Well)

ONSITE DURATION

9 days

LOCATION

Colindale

REQUIREMENT

A rainwater attenuation pump set was required for a new residential development of 100 units, with a controlled flow restriction as designated by the local water authority. Stainless steel frames were required to fix the pumps and valves in place, and to support the pipework and fittings which would connect to the pre-existing concrete tanks.





METHOD

- Following a full site survey by an Edincare Project Coordinator and consultation with the client and local water authority, hard-wearing dual pumps were specified which would be reliable and long-lasting.
- Pipework and cable were routed and installed. Controls were provided to draw water evenly from the attenuation tanks. A series of gate valves were installed for further flow control and to simplify maintenance. Flow meters were fitted to constantly monitor flow.
- All aspects of the installation work was carried out by a single multiskilled Edincare team with confined space safety training.

RESULT

- The system is very user-friendly. The dry well mounting and gate valves ensure easy servicing and a high degree of control, and the flow meters allow easy monitoring. Hard wearing dual pumps ensure increased reliability and longevity.

FOCUS ON

DRY WELL PUMPING STATIONS

In dry well pumping stations, the pumps and many of the other components are located externally to the sump.

They contrast with packaged pumping stations which use submersible pumps.

They suit projects where regular and convenient access to the pumps and equipment is required. As fewer parts are installed in the tank, servicing is quicker and a two-person confined entry team is not required as often.

While not as compact as a packaged pumping station, where space allows, they are very convenient.

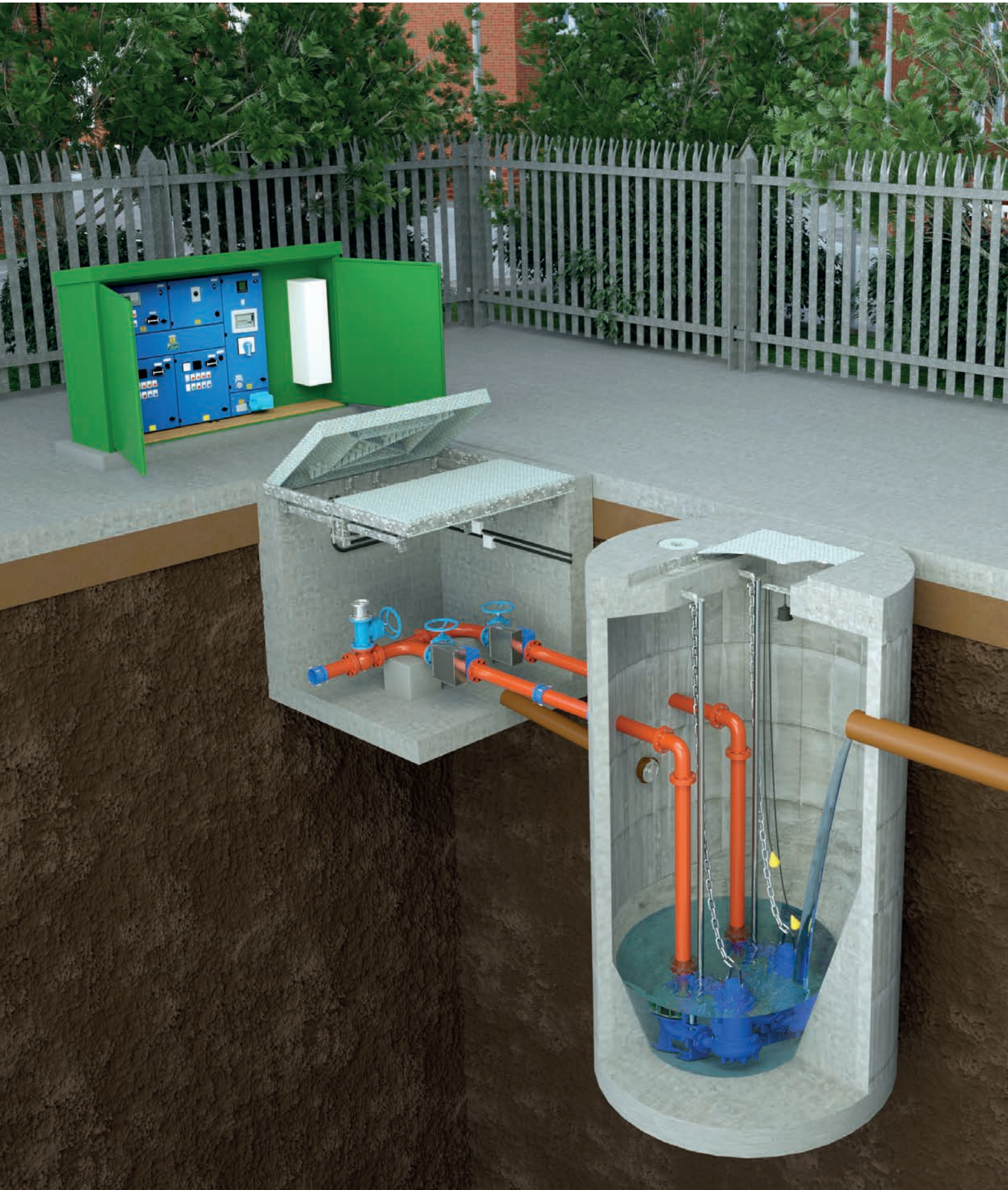

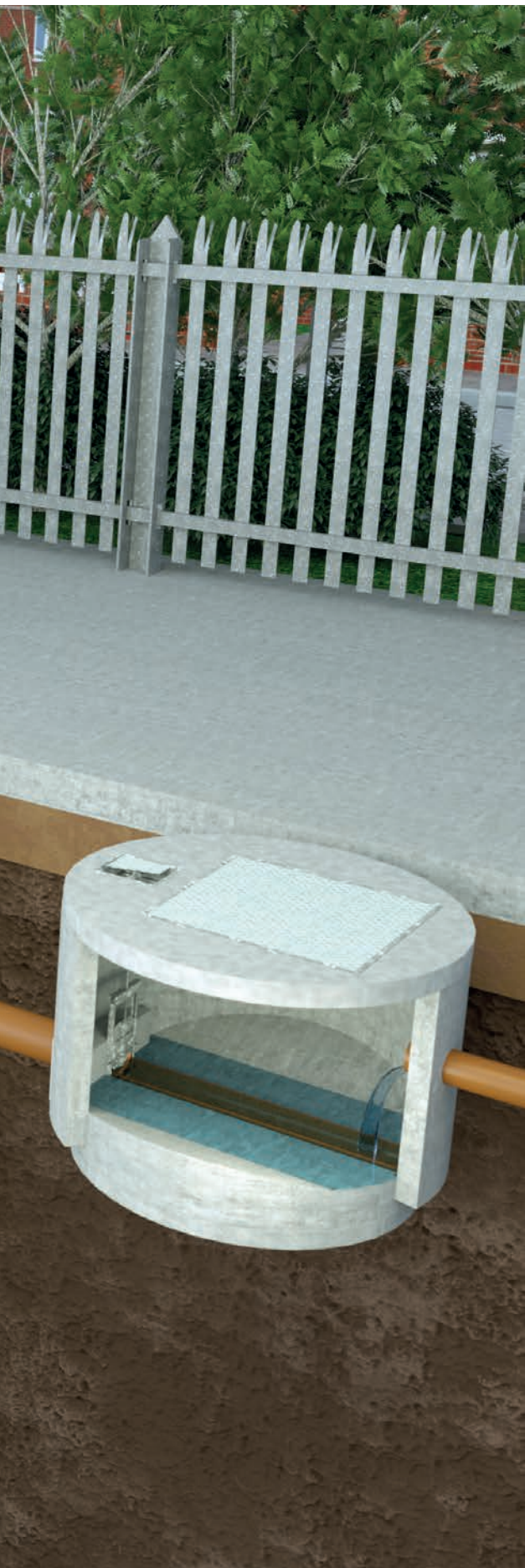

Adoptable pumping stations

For large housing developments, it is very often practical to construct a pumping station which can eventually be adopted by the local water authority. The Sewers for Adoption Guide which is published by WRc plc, defines the technical specifications. Most local water authorities will also require their own amendments to the design.

We offer services that include the design/ specification, installation and commissioning of adoptable pumping stations suitable for adoption by the local water authority, complying with all regulations. We have worked closely with the water authorities for many years enabling us to offer our customers a comprehensive service when it comes to the delivery of adoptable pumping stations.

**For more information call
Edincare Pumps today on**

01442 211554

Site Specification Sheet

CUSTOMER / SITE DETAILS

Name

Company

Address

Postcode

Telephone

Email

Date / /

Site contact

Address

Postcode

Telephone

Email

APPLICATION

FOUL / WASTE WATER

Appliance	N ^o . of	I/s	Appliance	N ^o . of	I/s
W.C.	<input type="text"/>	x 0.119	Urinal	<input type="text"/>	x 0.19
Wash basin	<input type="text"/>	x 0.38	Utility sink	<input type="text"/>	x 0.84
Bath	<input type="text"/>	x 0.38	Dishwasher	<input type="text"/>	x 0.25
Shower	<input type="text"/>	x 0.19	Wash. machine	<input type="text"/>	x 0.7
Bidet	<input type="text"/>	x 0.19			

INSTALLATION DETAILS

Occupants persons

Inlet Depth (A) mm

Vertical Lift (B) mm

Horizontal Run (C) mm

Inlet Size mm

Power 240V 415V

Distance to Control Panel m

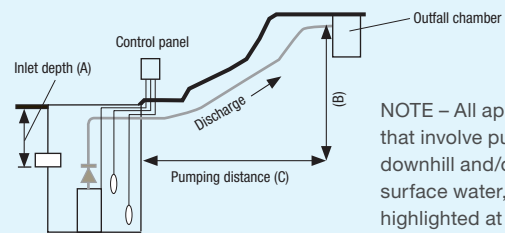

NOTE - All applications that involve pumping downhill and/or surface water, must be highlighted at the earliest possible moment.

SURFACE WATER

Surface type	Area		Area
Roof	<input type="text"/> m ²	Carriageway	<input type="text"/> m ²
Paved yard	<input type="text"/> m ²	Garden land	<input type="text"/> m ²
Footway	<input type="text"/> m ²		

GROUND WATER

Perimeter drainage channels

No. of pump stations 1 per 50m of linear channel

Sub-floor drainage (modular systems)

No. of pump stations 1 per 150m² floor area

Total area of basement floor m²

Total area of basement walls m²

Is the water table above the basement slab? Yes No

m² of surface water from lightwell

Product Specified

Specifier's Name

Date

 / /

Flow & Measurement Chart

FLOW & PRESSURE APPROXIMATE EQUIVALENTS

PRESSURES

Bar (kg/cm ²)	Metres of water	PSI	Feet of water	Atmospheres
0.5	5	7.25	16.73	0.49
1.0	10	14.50	33.45	0.97
1.5	15	21.75	50.18	1.48
2.0	20	29.00	66.91	1.97
2.5	25	36.25	83.64	2.47
3.0	30	43.51	100.36	2.96
3.5	35	50.76	117.10	3.45
4.0	40	58.01	133.82	3.95
4.5	45	65.26	150.55	4.44
5.0	50	72.51	167.27	4.93

- Bars (kg per sq. cm)**
 - × 10 = Metres of water
 - × 33.45 = Feet of water
 - × 14.5 = Pounds per square inch
 - × 0.97 = Atmospheres
- Metres of water**
 - × 0.1 = Bars (kg per sq. cm)
 - × 3.281 = Feet of water
 - × 1.422 = Pounds per square inch
 - × 0.097 = Atmospheres
- Pounds per sq. inch (PSI)**
 - × 0.07 = Bars (kg per sq. cm)
 - × 0.703 = Metres of water
 - × 2.3 = Feet of water
 - × 0.068 = Atmospheres
- Feet of water**
 - × 0.03 = Bars (kg per sq. cm)
 - × 0.305 = Metres of water
 - × 0.434 = Pounds per square inch
 - × 0.029 = Atmospheres
- Atmospheres**
 - × 1.003 = Bars (kg per sq. cm)
 - × 10.33 = Metres of water
 - × 33.9 = Feet of water
 - × 14.7 = Pounds per square inch

FLOW RATES

GPM	LPM	LPM	GPM
1.0	4.545	5.0	1.10
2.0	9.09	10.0	2.20
3.0	13.64	15.0	3.30
4.0	18.18	20	4.40
5.0	22.73	25	5.50
6.0	27.27	30	6.60
7.0	31.82	35	7.70
8.0	36.36	40	8.80
9.0	40.91	45	9.90
10.0	45.45	50	11.00

- Gallons per minute** × 4.545 = Litres per minute
- Litres per minute** × 0.22 = Gallons per minute
- Litres per minute** × 13.2 = Gallons per hour
- Metres³ per hour** × 0.28 = Litres per second
- Litres per second** × 3.6 = Metres³ per hour
- Metres³ per second** × 1000 = Litres per second
- Metres³ per minute** × 16.7 = Litres per second
- Litres per hour** × 1000 = Metres³ per hour

USEFUL APPROXIMATE EQUIVALENTS

VOLUME

- 1cm³ = 0.061in³
- 1inch³ = 16.387cm³
- 1ft³ = 0.028m³
- 1m³ = 35.315ft³
- 1m³ = 1000 litres
- 1m³ = 220 gallons
- 1litre = 0.035ft³
- 1litre = 0.220 gallons
- 1litre = 0.001m³
- 1litre = 1000 cm³
- 1gallon = 4.545 litres
- 1gallon = 0.004545m³

AREA

- 1cm² = 0.155in²
- 1in² = 6.452cm²
- 1ft² = 0.093m²
- 1m² = 10.764ft²
- 1m² = 10,000cm²
- 1 hectare = 10,000m²
- 1km² = 100 hectares
- 1km² = 0.386 square mile
- 1mile² = 2.590km²

LENGTH

- 1mm = 0.039in
- 1cm = 0.394in
- 1in = 2.540cm
- 1ft = 0.305m
- 1ft = 12in
- 1m = 3.281ft
- 1km = 0.621 miles
- 1mile = 1.609km

WEIGHT

- 1oz = 28.35g
- 1lb = 16oz
- 1lb = 0.454kg
- 1kg = 2.205lb
- 1kg = 1000g
- C = Celsius or Centigrade
- F = Fahrenheit
- C = (F - 32) ÷ 1.8
- F = (1.8 × C) + 32

TEMPERATURE

°C	°F
-17.8	0
-10	14
0	32
10	50
20	68
30	86
40	104
50	122
60	140
70	158
80	176
90	194
100	212

Notes

A series of horizontal dotted lines for writing notes.

DELIVERING PUMPED SOLUTIONS NATIONWIDE

Edincare Pumps has been established for over 25 years specialising in the manufacture, project design, sale, commission, service and repair of pumped solutions.

OUR PRODUCT RANGE

- Packaged pumping stations
- Waste water pumping systems
- Macerators and macerating toilets
- Floor mounted pumping stations
- Fat, oil and grease separating systems
- Rainwater harvesting systems
- Battery backup systems
- Adoptable pumping stations
- Accessories

Delivering Pumped Solutions Nationwide

MANUFACTURING • PROJECT DESIGN • SALES • COMMISSIONING • SERVICING • REPAIR



Our policy is one of continuous product improvement, we reserve the right to change specifications and prices without prior notice. All information is given in good faith. No responsibility can be accepted for errors, omissions or incorrect assumptions. © Copyright 2019 Omni Pump International Ltd t/a Edincare Pumps. All rights reserved.



Unit 8, Heron Business Park
Eastman Way, Hemel Hempstead
Hertfordshire, HP2 7FW

01442 211554

01442 211553

info@edincare.com

www.edincare.com

linkedin.com/company/edincarepumps

twitter.com/edincarepumps